

**SONY**

**TRINITRON**  
**Character Display**  
CPD-1303

Operating Instructions page 2

Mode d'emploi page 14

**MULTISCAN**

The model and serial numbers are located at the rear. Record these numbers in the spaces provided below. Refer to these numbers whenever you call upon your dealer regarding this product.

Model No. \_\_\_\_\_ Serial No. \_\_\_\_\_

## **WARNING**

To prevent fire or shock hazard, do not expose the unit to rain or moisture.

Dangerously high voltages are present inside the unit. Do not open the cabinet. Refer servicing to qualified personnel only.

### **INFORMATION**

This equipment generates and uses radio frequency energy and if not installed and used properly, that is, in strict accordance with the manufacturer's instructions, may cause interference to radio and television reception. It has been type tested and found to comply with the limits for a Class B computing device in accordance with the specifications in Subpart J of Part 15 of FCC Rules, which are designed to provide reasonable protection against such interference in a residential installation. However, there is no guarantee that interference will not occur in a particular installation. If this equipment does cause interference to radio or television reception, which can be determined by turning the equipment off and on, the user is encouraged to try to correct the interference by one or more of the following measures:

- Reorient the receiving antenna
- Relocate the equipment with respect to the receiver
- Move the equipment away from the receiver
- Plug the equipment into a different outlet so that equipment and receiver are on different branch circuits.

If necessary, the user should consult the dealer or an experienced radio/television technician for additional suggestions. The user may find the following booklet prepared by the Federal Communications Commission helpful:

"How to identify and Resolve Radio-TV Interference Problems." This booklet is available from the U.S. Government Printing Office, Washington, DC 20402, Stock No. 004-000-00345-4.

A shielded interface cable such as the SMF-series recommended on page 8 must be used with this equipment.

### **For the customers in Canada**

This apparatus complies with the Class B limits for radio noise emissions set out in Radio Interference Regulations.

The CPD-1303 is a high resolution character display designed for use with microcomputers, or character generators having either analog or digital RGB output.

## **Features**

- Fine Pitch Trinitron character display with a dark screen.
- An RGB terminal which allows equipment with either analog or digital RGB output to be connected.
- Compatible with the IBM 3270 and IBM PC, AT, XT, and PS/2 microcomputers using the CGA, EGA, PGA, MDA, and VGA.

## **Table of Contents**

Precautions .....	4
Location and Function of Controls .....	5
Connections .....	8
Use of the Tilt-Swivel .....	9
Specifications .....	10
Timing Charts .....	12

# Precautions

## On safety

- Operate the unit only on 120V AC, 60 Hz.
- Should any liquid or solid object fall into the cabinet, unplug the unit and have it checked by qualified personnel before operating it any further.
- Unplug the unit from the wall outlet if it is not to be used for several days.
- To disconnect the AC power cord, pull it out by the plug. Never pull the cord itself.

## On installation

- Allow adequate air circulation to prevent internal heat build-up. Do not place the unit on surfaces (rugs, blankets, etc.) or near materials (curtains, draperies) that may block the ventilation holes.
- Do not install the unit in a location near heat sources such as radiators or air ducts, or in a place subject to direct sunlight, excessive dust, mechanical vibration or shock.

## On cleaning

To keep the unit looking brand-new, periodically clean it with a soft cloth. Stubborn stains may be removed with a cloth lightly dampened with a mild detergent solution. Never use strong solvents such as thinner or benzene, or abrasive cleansers since these will damage the cabinet. As a safety precaution, unplug the unit before cleaning it.

## On repacking

Do not throw away the carton and packing materials. They make an ideal container in which to transport the unit. When shipping the unit to another location, repack it as illustrated on the carton.

If you have any questions about this unit, contact your authorized Sony dealer.

# Location and Function of Controls

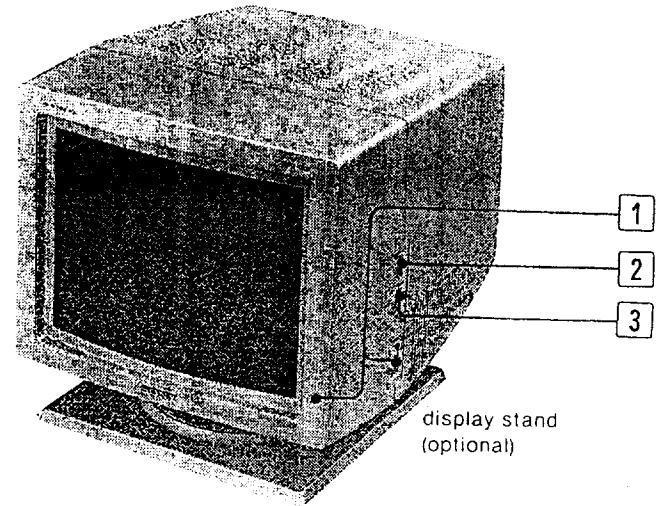

**1 POWER switch and indicator (green)**

To turn on the power of the unit, press this switch to ON. The indicator will light up. To turn off the unit, press towards OFF.

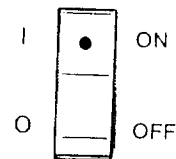

**2 PICTURE control**

Adjusts the contrast. Turn downwards to increase contrast, or upwards for less contrast.

**3 BRIGHTNESS control**

Normally keep this control at the center detent position. For a brighter display, turn this knob downwards, or for a darker display, turn it upwards.

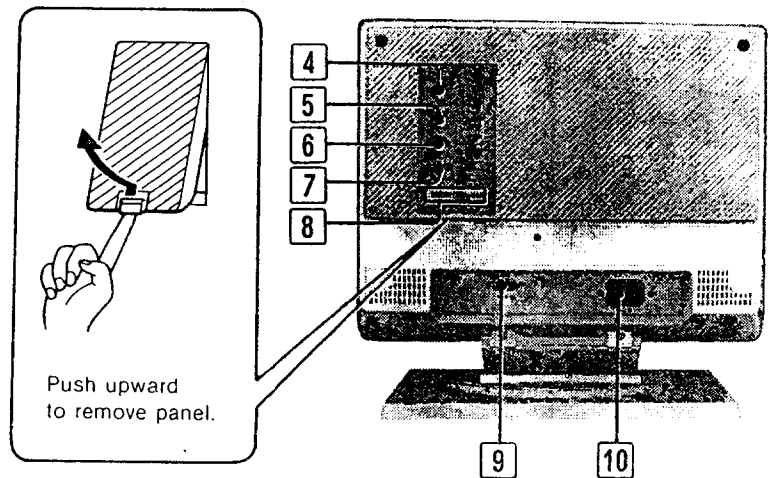

- 4 H SHIFT (horizontal shift) control**  
Turn this control to center the displays of microcomputers, character generators, etc. that are shifted toward the left or right side of the screen.
- 5 V SHIFT (vertical shift) control**  
Turn this control to eliminate any shifting in the vertical direction.
- 6 H SIZE (horizontal size) control**  
Turn this control to adjust the horizontal size.
- 7 V SIZE (vertical size) control**  
Turn this control to adjust the vertical size.

**8 RGB input selectors**

Depending on the RGB output of the equipment you have connected, set these switches to one of the following four positions.

**ANALOG:** For microcomputers having analog RGB output, such as those using the PGA card. The position of the left switch has no effect when the right switch is set to ANALOG.

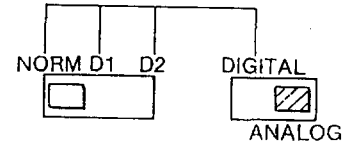

**NORM-DIGITAL:** For microcomputers having TTL RGB output, such as the IBM 3270.

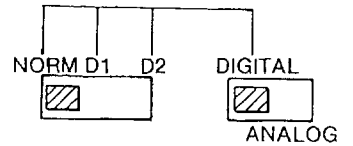

**D1-DIGITAL:** For microcomputers having TTL RGB and I signal output, such as the IBM PC, AT and XT using the standard color graphics card.

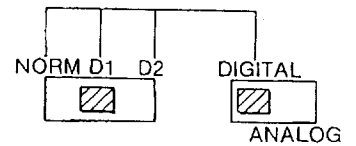

**D2-DIGITAL:** For TTL graphics cards on the IBM PC, AT and XT. (automatic adjustment between EGA, CGA and MDA)

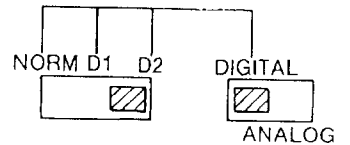

**9 RGB IN (input) connector (9-pin D-sub)**

Allows a microcomputer having either analog or digital RGB output to be connected. Refer to page 8.

**10 AC IN connector**

Connect to the AC outlet with the supplied AC power cord.

# Connections

Use an appropriate optional color monitor cable with 9-pin D-sub connectors shown in the table.

Be sure to turn the power of the unit off before making any connections.

Equipment that can be connected	Monitor cable (optional) to be used	Position of RGB input selectors of the CPD-1303
IBM PC, AT, XT with CGA	SMF-512C (SMF-520)	D1-DIGITAL
IBM PC, AT, XT with EGA, CGA, MDA	SMF-512C (SMF-520)	D2-DIGITAL
IBM 3270	SMF-514	NORM-DIGITAL
IBM PC, AT, XT with VGA	SMF-513	ANALOG

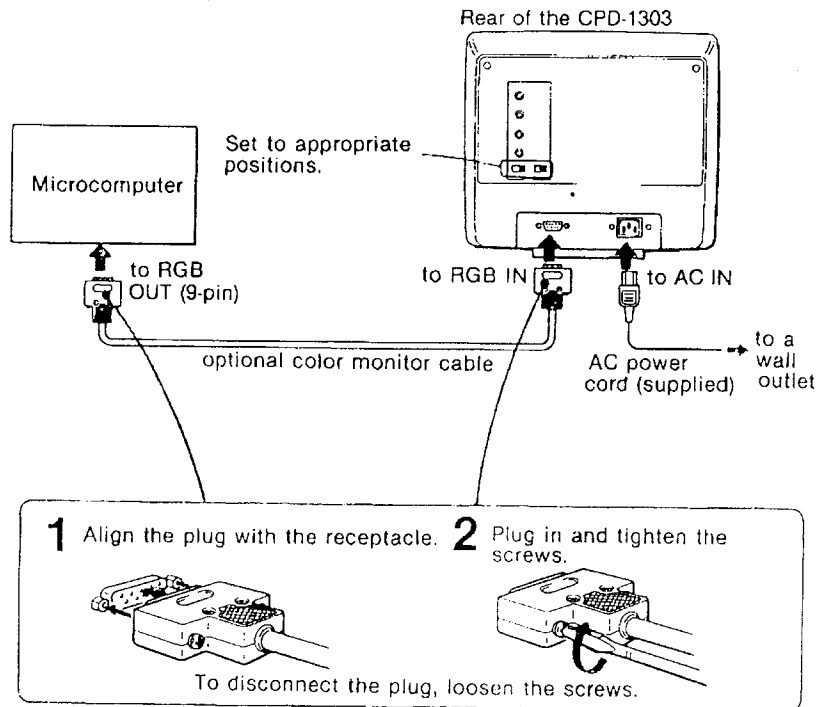



**Note**

The monitor cable should arrange the RGB output signals of the connected equipment so that they match the signal assignment of the RGB IN connector of this unit (See page 11). If you are not sure whether you can use your computer or character generator with CPD-1303 or which monitor cable to use, consult your authorized dealer.

## Use of the Tilt-Swivel

With the optional Sony SU-542 tilt-swivel, this unit can be adjusted to be viewed at your desired angle within 90° horizontally and 15° vertically.

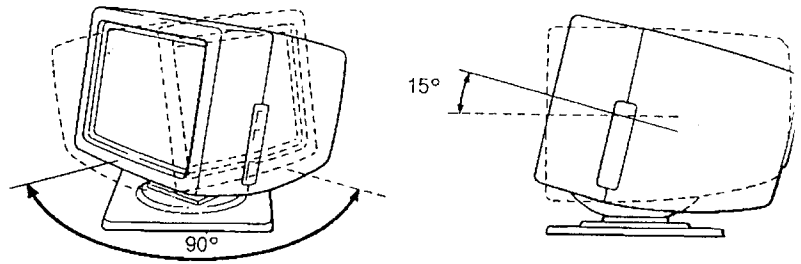

For details, read the instructions of the tilt-swivel.

# Specifications

Picture tube	Fine Pitch Trinitron color tube 13-inch picture tube measured diagonally 90 degree deflection Useful screen 270mm x 201mm Phosphor P22 Phosphor pitch 0.38mm
Viewable Pixels	800 x 600
Scanning frequency	Vertical sync signal frequency: 50 - 100 Hz Horizontal sync signal frequency: 15.0 - 34.0 kHz
Input	RGB input (D-sub 9 pin) (Analog and TTL available)
Power requirements	120V AC, 50/60 Hz
Power consumption	96 W (maximum)
Dimensions	360 x 300 x 427 mm (w/h/d) (14 <sup>1</sup> / <sub>4</sub> x 11 <sup>7</sup> / <sub>8</sub> x 16 <sup>3</sup> / <sub>4</sub> inches) including projecting parts
Weight	14.5 kg (32 lb)
Supplied accessory	AC power cord (1)

## Optional accessories

Monitor cable (9-pin ↔ 9-pin)	SMF-512C SMF-513 SMF-514 SMF-520
Tilt/Swivel	SU-542 Display Stand

Design and specifications subject to change without notice.

## Pin Assignment

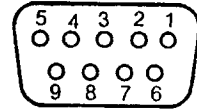

		1	2	3	4	5	6	7	8	9	
ANALOG**		GND	GND	R	G*	B	GND	—	H/HV	V	
DIGITAL	NORMAL	GND	GND	R	G	B	GND	—	H/HV	V	
	D1	GND	GND	R	G	B	I	—	H/HV	V	
	D2	CGA	GND	GND	R	G	B	I	—	H/HV	V
		MDA	GND	GND	—	—	—	I	G	H/HV	V
EGA	GND	r	R	G	B	g	b	H/HV	V		

(Input Selection)

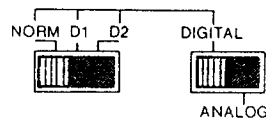

GND: Ground R: Red Signal G: Green Signal  
 B: Blue Signal —: No connection  
 H: Horizontal Sync V: Vertical Sync  
 HV: Composite sync I: Intensity Signal  
 r: Secondary Red for EGA 64 colors  
 g: Secondary Green for EGA 64 colors  
 b: Secondary Blue for EGA 64 colors

### ANALOG

\* Sync on Green automatic if horizontal or composite sync is not assigned at Pin #8

\*\* IBM PGA should be connected with PGA Video cable (SMF-513)

### DIGITAL (TTL LEVEL)

"Normal" is for 8 colors (R, G, & B)

"D1" is for 16 colors (R, G, B & I)

"D2" is for IBM Digital Color Graphic Boards (CGA, MDA, EGA) and there is no need to readjust anything among these cards.

### SYNC

Composite sync is acceptable at Pin #8.

Every polarity is acceptable at Pin #8 & 9.

### VERTICAL Size

Vertical size depends on vertical frequency and can be manually adjusted.

# Timing Charts (for approximate reference)

## 1 D2-1 (IBM CGA compatible)

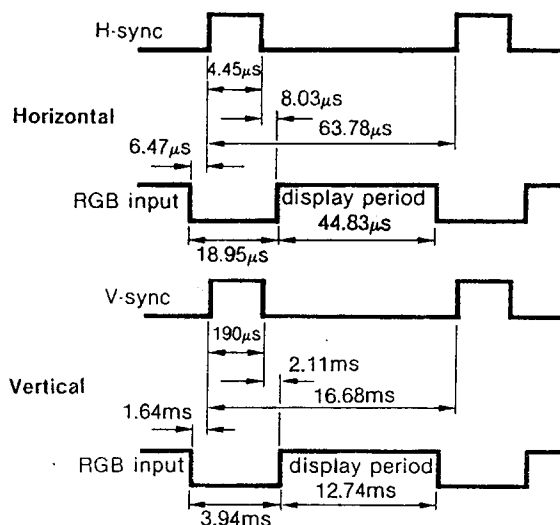

The indicated values apply when the line period is 63.78  $\mu\text{s}$  and the field period is 16.68 ms.

## 2 D2-2 (IBM EGA compatible)

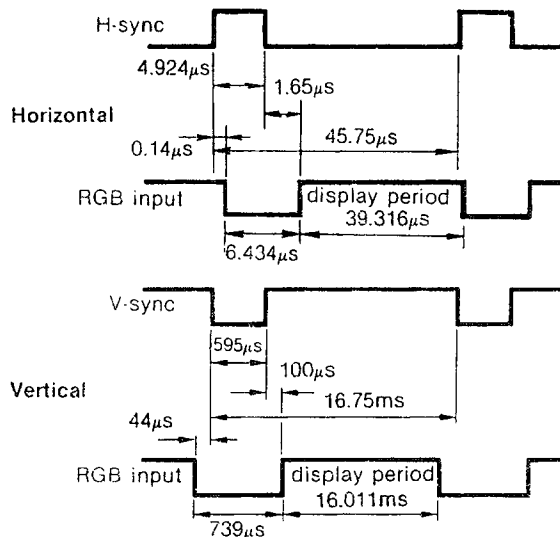

The indicated values apply when the line period is 45.75  $\mu\text{s}$  and the field period is 16.75 ms.

3 D2-3 (IBM PGA compatible)

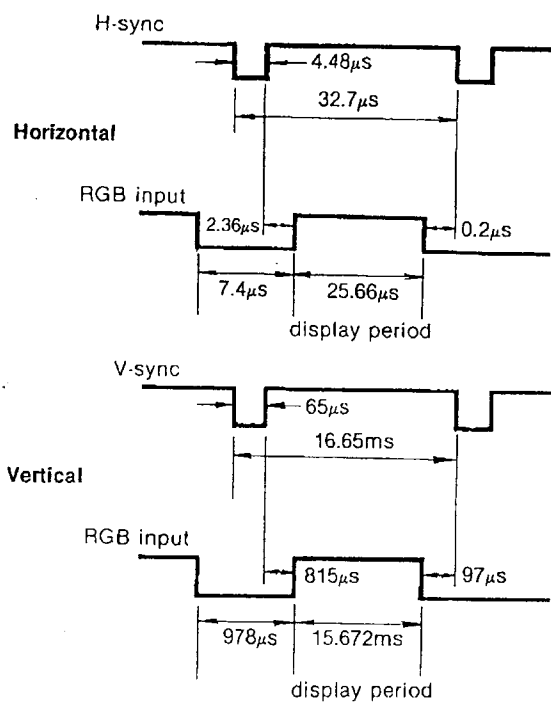

The indicated values apply when the line period is  $32.7\mu\text{s}$  and the field period is  $16.65\text{ms}$ .

**Note**

The picture may be biased or the picture size may be changed depending on the timing of the connected equipment.

## **AVERTISSEMENT**

Ne jamais exposer l'appareil à la pluie ni le laisser dans un milieu humide car ceci favoriserait éventuellement un amorçage électrique ou une électrocution.

De hautes tensions circulent dans les circuits internes et ceci constitue un danger potentiel.

Ne jamais ouvrir le coffret de l'appareil. Confier les réglages et les dépannages à un technicien qualifié.

### **Pour les utilisateurs au Canada**

Cet appareil est conforme aux normes Classe B pour bruits radioélectriques, spécifiés dans le Règlement sur le brouillage radioélectrique.

Le CPD-1303 est un visuel de caractère à haute définition, spécialement conçu pour être utilisé avec les micro-ordinateurs ou les générateurs de caractère munis d'une sortie RGB analogique ou numérique.

## Caractéristiques dominantes

- Visuel de caractère Trinitron à haute définition muni d'un écran noir.
- Connecteur RGB assurant le raccordement de tout équipement muni d'un connecteur de sortie RGB analogique ou numérique.
- Compatible avec le 3270 IBM et les micro-ordinateurs PC, AT, XT et PS/2 IBM au moyen des cartes CGA, EGA, PGA, MDA et VGA.

## Table des matières

Précautions .....	16
Emplacement et fonction des commandes .....	17
Branchements .....	20
Utilisation du support inclinable-orientable .....	21
Spécifications .....	22
Diagrammes de temps .....	24

# Précautions

## Sécurité

- L'appareil fonctionne uniquement sur une tension d'alimentation secteur de 120V, 60 Hz.
- Si de menus objets ou un liquide quelconque pénètrent à l'intérieur de l'appareil, le débrancher immédiatement et le faire vérifier par un dépanneur professionnel avant de le remettre en service.
- Isoler l'appareil du secteur quand il n'est pas appelé à fonctionner pendant plusieurs jours.
- Pour débrancher le cordon secteur, saisir la fiche et débrancher. Ne jamais tirer seulement sur le cordon pour débrancher.

## Installation

- Assurer une circulation d'air suffisante à l'appareil pour empêcher tout accroissement thermique interne. Ne pas le poser sur une surface (tapis ou napperons) ou près de matériaux (rideaux, tentures, etc.) risquant de boucher les ouvertures d'aération.
- Ne pas placer l'appareil près de sources de chaleur telles que des radiateurs ou des gaines de ventilation ou directement au soleil; éviter aussi la présence excessive de poussière et de vibrations d'origine mécanique.

## Entretien

Pour que l'appareil conserve en permanence son aspect neuf, nettoyer régulièrement le coffret et les plaques avec un morceau d'étoffe sèche. Les taches plus tenaces peuvent être retirées avec un morceau d'étoffe souple et légèrement imprégnée d'une solution détergente neutre. Ne pas se servir de solvant, diluant à peinture, benzine ou produits d'entretien abrasifs, ces produits risquant d'attaquer la finition extérieure. Par mesure de sécurité, débrancher la cordon secteur avant de procéder à l'entretien de l'appareil.

## Remballage

Ne pas se défaire du carton d'emballage de l'appareil ni des éléments de calage. C'est encore le meilleur moyen d'emballage qui permet de transporter l'appareil en toute sécurité. Si l'appareil doit être expédié, le remettre dans son emballage d'origine en procédant comme indiqué sur le carton.

Le concessionnaire autorisé Sony est tout à fait qualifié pour répondre à toute question concernant l'appareil.



# Emplacement et fonction des commandes

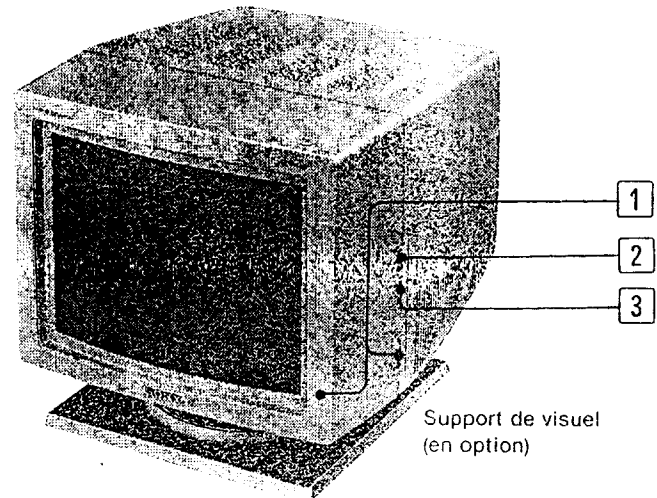

**1** Interrupteur d'alimentation et témoin (vert) (POWER)

Pour mettre l'appareil sous tension, appuyer sur l'interrupteur (ON). Le témoin s'allume aussitôt. Pour le mettre hors tension, appuyer de nouveau dessus (OFF).

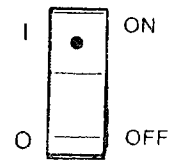

**2** Réglage de contraste (PICTURE)

Règle le contraste. Tourner le réglage vers le bas pour augmenter le contraste ou vers le haut pour le réduire.

**3** Réglage de luminosité (BRIGHTNESS)

Normalement, ce réglage est placé sur la position centrale crantée. L'image apparaissant sur l'écran est plus claire lorsque le réglage est tourné vers le bas, elle est plus sombre lorsque le réglage est tourné vers le haut.

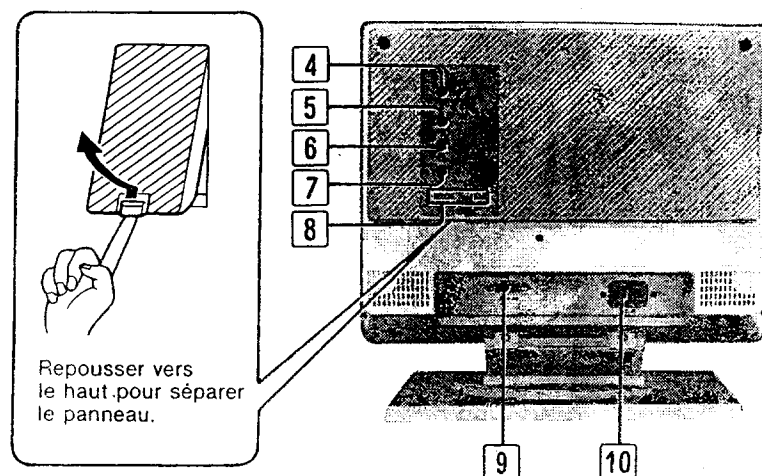

- 4 Réglage de déplacement horizontal (H SHIFT)**  
 Tourner le réglage pour centrer l'image décalée vers la gauche ou vers la droite de l'écran, provenant d'un micro-ordinateur ou d'un générateur de caractère.
- 5 Commande de déplacement vertical (V SHIFT)**  
 Tourner la commande pour éliminer tout déplacement vertical.
- 6 Commande de largeur (H SIZE)**  
 Tourner cette commande pour régler la largeur.
- 7 Commande de hauteur (V SIZE)**  
 Tourner cette commande pour régler la hauteur.

### 8 Sélecteurs d'entrée RGB

Selon le connecteur de sortie RGB des équipements raccordés, placer les sélecteurs sur l'une des 4 positions suivantes:

**ANALOG:** réservée aux micro-ordinateurs possédant un connecteur de sortie RGB analogique, par exemple ceux utilisant la carte PGA.

Le réglage du sélecteur de gauche est sans effet lorsque le sélecteur de droite est sur ANALOG.

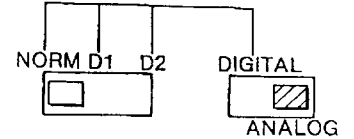

**NORM-DIGITAL:** réservée aux micro-ordinateurs à sortie RGB TTL, tels que le 3270 IBM.

**D1-DIGITAL:** réservée aux micro-ordinateurs à sortie RGB TTL et signal I, tels que PC, AT et XT IBM utilisant une carte graphique couleur standard.

**D2-DIGITAL:** réservée aux PC, AT et XT IBM à carte graphique TTL (réglage automatique pour les cartes EGA, CGA et MDA).

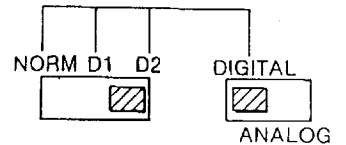
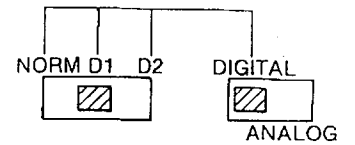
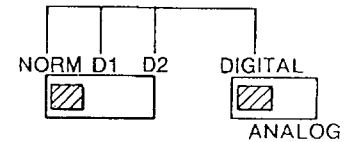

### 9 Connecteur d'entrée RGB (RGB IN) (9 broches D-sub)

Assure le raccordement d'un micro-ordinateur ou d'un générateur de caractère possédant un connecteur de sortie RGB analogique ou numérique. Se référer à la page 20.

### 10 Prise d'alimentation secteur (AC IN)

Se branche sur une prise secteur à l'aide du cordon d'alimentation secteur fourni.

# Branchements

Utiliser le câble de moniteur couleur en option approprié avec les connecteurs D-sub à 9 broches montrés dans le tableau.  
 Bien couper l'alimentation de l'appareil avant d'effectuer les branchements.

Appareils connectables	Câble de moniteur (en option) nécessaire	Positions des sélecteurs d'entrée RGB du CPD-1303
IBM PC, AT, XT avec CGA	SMF-512C (SMF-520)	D1-DIGITAL
IBM PC, AT, XT avec EGA, CGA, MDA	SMF-512C (SMF-520)	D2-DIGITAL
IBM 3270	SMF-514	NORM-DIGITAL
IBM PC, AT, XT avec PGA	SMF-513	ANALOG

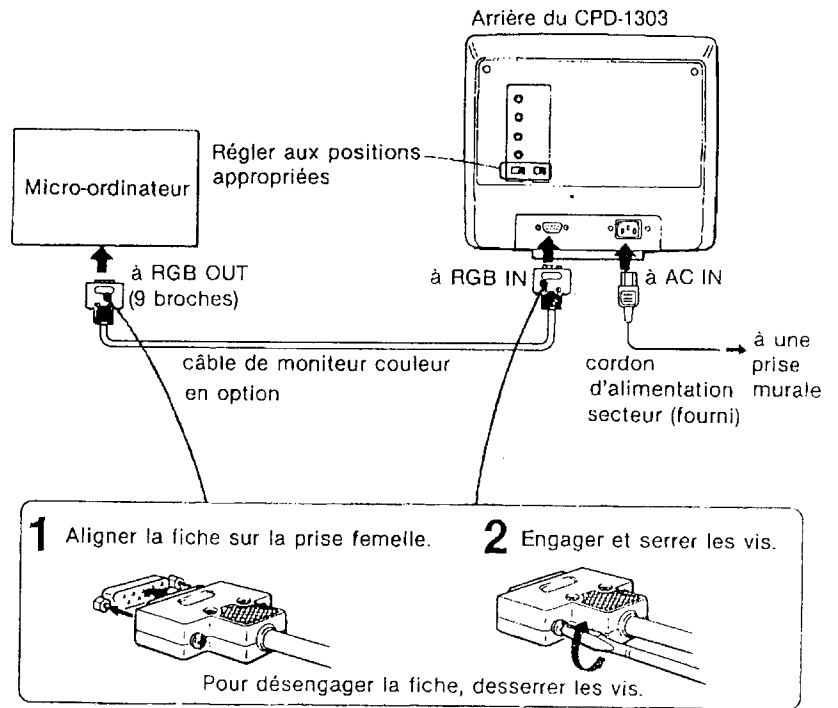

#### Remarque

Le câble de moniteur utilisé doit correspondre aux signaux de sortie RGB de l'équipement raccordé de façon à ce qu'ils correspondent à l'affectation des signaux du connecteur RGB IN de cet appareil (voir la page 23). En cas de doute sur la possibilité d'utilisation d'un micro-ordinateur ou d'un générateur de caractère avec le CPD-1303 ou sur le choix du câble de moniteur, se renseigner auprès du revendeur autorisé.

## Utilisation du support inclinable-orientable

Grâce au support inclinable-orientable Sony SU-542 (en option), cet appareil peut être orienté librement afin d'obtenir l'inclinaison idéale de visionnement dans les limites de 90° dans le plan horizontal et de 15° dans le plan vertical.

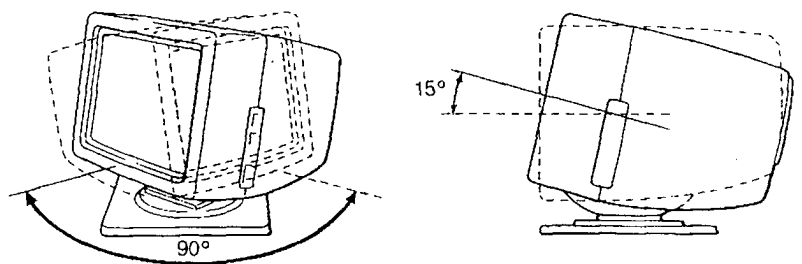

Lire le mode d'emploi du support inclinable-orientable, pour de plus amples détails.

# Spécifications

Tube Image	Tube couleur Trinitron à haute définition Tube image de 13 pouces (diagonal) Déviation de 90 degrés Surface utile de l'écran 270 × 201 mm Phosphore P22 Point de dépôt de phosphore 0,38 mm
Pixel perçu	800 × 600
Fréquence d'analyse	Fréquence de signal de synchro vertical: 50 - 100 Hz Fréquence de signal de synchro horizontal: 15,0 - 34,0 kHz
Entrée	Entrée RGB (à 9 broches D-sub) (Analogique et TTL disponibles)
Alimentation	Secteur 120V, 50/60 Hz
Consommation	96W (maxi)
Dimensions hors tout	360 × 300 × 427 mm (l/h/p) (14 <sup>1</sup> / <sub>4</sub> × 11 <sup>7</sup> / <sub>8</sub> × 16 <sup>3</sup> / <sub>4</sub> pouces)
Poids	14,5 kg (32 li.)
Accessoire fourni	Cordon d'alimentation secteur (1)

## Accessoires optionnels

Câble de moniteur (9 broches ↔ 9 broches)

SMF-512C

SMF-513

SMF-514

SMF-520

Support inclinable-orientable

Support de visuel SU-542

La conception et les spécifications peuvent être modifiées sans préavis.

## Affectation des broches

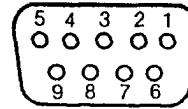

		1	2	3	4	5	6	7	8	9	
ANALOG**		GND	GND	R	G*	B	GND	—	H/HV	V	
DIGITAL	NORMAL	GND	GND	R	G	B	GND	—	H/HV	V	
	D1	GND	GND	R	G	B	I	—	H/HV	V	
	D2	CGA	GND	GND	R	G	B	I	—	H/HV	V
		MDA	GND	GND	—	—	—	I	G	H/HV	V
	EGA	GND	r	R	G	B	g	b	H/HV	V	

(Sélection d'entrées) GND: Terre R: Signal rouge G: Signal vert  
 B: Signal bleu —: pas de branchement  
 H: Sync horizontale V: Sync verticale  
 HV: Sync composite I: Signal intensité  
 r: Rouge secondaire pour EGA 64 couleurs  
 g: Vert secondaire pour EGA 64 couleurs  
 b: Bleu secondaire pour EGA 64 couleurs

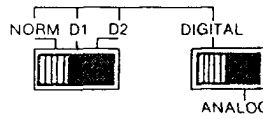

### ANALOG

- \* Sync sur vert automatique si sync horizontale ou composite n'est pas affectée à la broche #8
- \*\* IBM PGA devrait être raccordé avec un câble PGA (SMF-513)

### DIGITAL (niveau TTL)

"Normal" pour 8 couleurs (R, G, et B)

"D1" pour 16 couleurs (R, G, B et I)

"D2" pour Planches Graphiques Numériques en Couleurs IBM (CGA, MDA, EGA) sans nécessité de régler de nouveau quoi que ce soit dans ces cartes.

### SYNC

Sync composite est acceptable à la broche #8.

Toute polarité est acceptable aux broches #8 & 9.

### Hauteur VERTICAL

La hauteur dépend de la fréquence verticale et peut être réglée manuellement.

# Diagramme de temps (Référence approximative)

## 1 D2-1 (IBM CGA compatible)

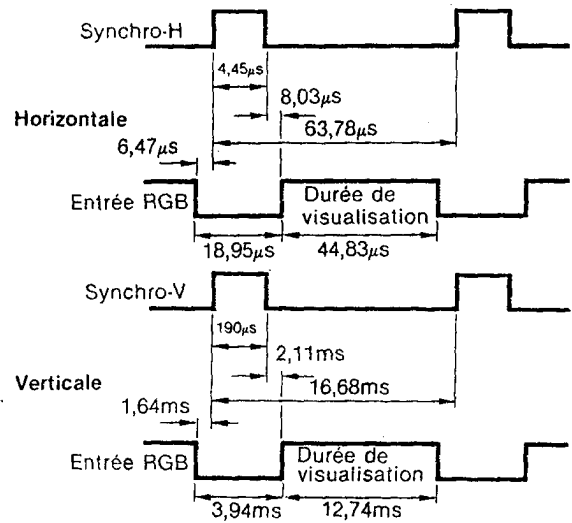

Les valeurs indiquées s'appliquent pour une durée de ligne de 63,78  $\mu\text{s}$  et une durée de trame de 16,68 ms.

## 2 D2-2 (IBM EGA compatible)

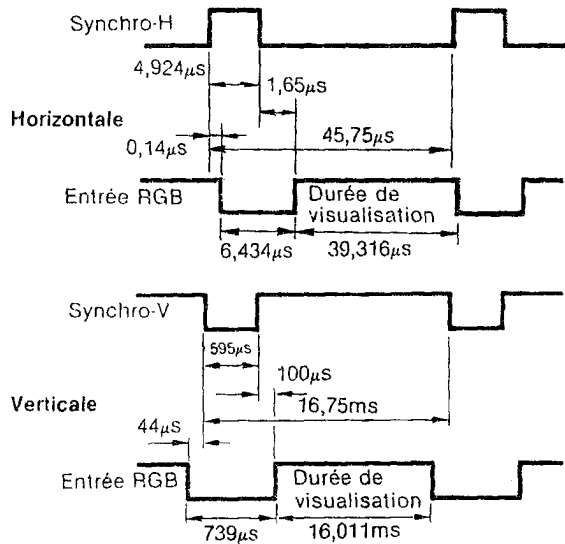

Les valeurs indiquées s'appliquent pour une durée de ligne de 45,75  $\mu\text{s}$  et une durée de trame de 16,75 ms.



**3 D2-3 (IBM PGA compatible)**

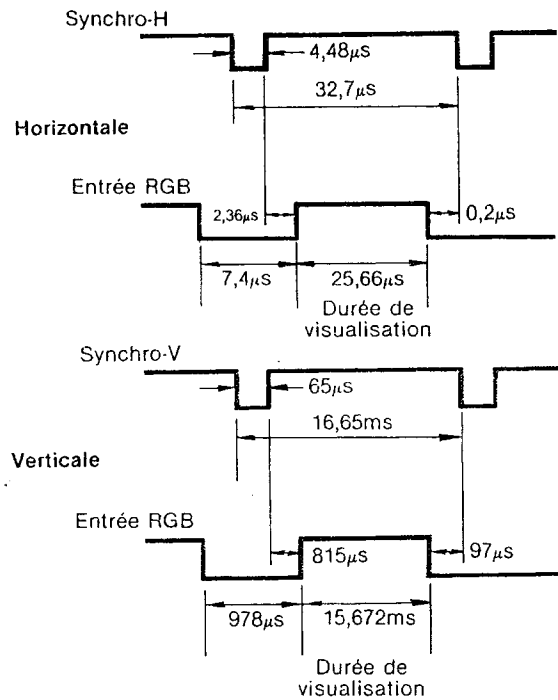

Les valeurs indiquées s'appliquent pour une durée de ligne de  $32,7\mu\text{s}$  et une durée de trame de  $16,65\text{ms}$ .

**Remarque**

Un parasitage ou un changement de dimension de l'image risque de se produire en fonction de la synchronisation de l'équipement raccordé.

# Owner's Record

The model and serial numbers are located at the rear of the unit. Record the serial number in the space provided below. Refer to these numbers whenever you call upon your dealer regarding this product.

Model No. GDM-17SE1/20SE1      Serial No. \_\_\_\_\_

## WARNING

To prevent fire or shock hazard, do not expose the unit to rain or moisture. Dangerously high voltages are present inside the set. Do not open the cabinet. Refer servicing to qualified personnel only.

This equipment has been tested and found to comply with the limits for a Class B digital device, pursuant to Part 15 of the FCC Rules. These limits are designed to provide reasonable protection against harmful interference in a residential installation. This equipment generates, uses, and can radiate radio frequency energy and, if not installed and used in accordance with the instructions, may cause harmful interference to radio communications. However, there is no guarantee that interference will not occur in a particular installation. If this equipment does cause harmful interference to radio or television reception, which can be determined by turning the equipment off and on, the user is encouraged to try to correct the interference by one or more of the following measures:

- Reorient or relocate the receiving antenna.
- Increase the separation between the equipment and receiver.
- Connect the equipment into an outlet on a circuit different from that to which the receiver is connected.
- Consult the dealer or an experienced radio/TV technician for help.

You are cautioned that any changes or modifications not expressly approved in this manual could void your authority to operate this equipment.

### For the customers in Canada

This apparatus complies with the Class B limits for radio noise emissions set out in Radio Interference Regulations.

### Pour les utilisateurs au Canada

Cet appareil est conforme aux normes Classe B pour bruits radioélectriques, spécifiés dans le Règlement sur le brouillage radioélectrique.

### INFORMATION

This product complies with Swedish National Council for Metrology (MPR) standards issued in December 1990 (MPR II) for very low frequency (VLF) and extremely low frequency (ELF).

### INFORMATION

Ce produit est conforme aux normes du Swedish National Council for Metrology de décembre 1990 (MPR II) en ce qui concerne les fréquences très basses (VLF) et extrêmement basses (ELF).

### Hinweis

Dieses Gerät erfüllt bezüglich tieffrequenter (very low frequency) und tiefstfrequenter (extremely low frequency) Strahlung die Vorschriften des „Swedish National Council for Metrology (MPR)“ vom Dezember 1990 (MPR II).

### INFORMACIÓN

Este producto cumple las normas del Consejo Nacional Sueco para Metrología (MPR) emitidas en diciembre de 1990 (MPR II) para frecuencias muy bajas (VLF) y frecuencias extremadamente bajas (ELF).

## Bescheinigung des Herstellers

Hiermit wird bescheinigt, daß der monitor GDM-17SE1/20SE1 in Übereinstimmung mit den Bestimmungen der BMPT-Amtsblatt Vfg 243/1991, Vfg 46/1992 funktentstört ist. Der vorschriftsmäßige Betrieb mancher Geräte (z.B. Meßsender) kann allerdings gewissen Einschränkungen unterliegen. Beachten Sie deshalb die Hinweise in der Bedienungsanleitung. Dem Bundesamt für Zulassungen in der Telekommunikation wurde das Inverkehrbringen dieses Gerätes angezeigt und die Berechtigung zur Überprüfung der Serie auf Einhaltung der Bestimmungen eingeräumt.

SONY Deutschland GmbH  
Hugo Eckener Str. 20 50829 Köln

## Hinweis

Gemäß der Amtsblätter des BMPT Nrn. 61/1991 und 6/1992 wird der Betreiber darauf aufmerksam gemacht, daß die von ihm mit diesem Gerät zusammengestellte Anlage auch den technischen Bestimmungen dieser Amtsblätter genügen muß.

## Hinweise

- Aus ergonomischen Gründen wird empfohlen, die Grundfarbe Blau nicht auf dunklem Untergrund zu verwenden (schlechte Erkennbarkeit, Augenbelastung bei zu geringem Zeichenkontrast).
- Aus ergonomischen Gründen sollten nur Darstellungen auf dunklem Hintergrund bei Vertikalfrequenzen ab 60 Hz (ohne Zeilensprung) benutzt werden.
- Die Konvergenz des Bildes kann sich auf Grund des Magnetfeldes am Ort der Aufstellung aus der korrekten Grundeinstellung verändern. Zur Korrektur empfiehlt es sich deshalb, die Regler an der Frontseite für H STAT und V STAT so einzustellen, daß die getrennt sichtbaren Farblinien für Rot, Grün und Blau bei z.B. der Darstellung eines Buchstabens zur Deckung (Konvergenz) gelangen. Siehe hierzu auch die Erklärungen zu H STAT und V STAT.

## NOTICE

This notice is applicable for USA/Canada only. If shipped to USA/Canada, install only a UL LISTED/CSA LABELLED power supply cord meeting the following specifications:

### SPECIFICATIONS

Plug Type	Nema-Plug 5-15p
Cord	Type SVT or SJT, minimum 3 x 18 AWG
Length	Maximum 15 feet
Rating	Minimum 7A, 125V

## NOTICE

Cette notice s'applique aux Etats-Unis et au Canada uniquement.

Si cet appareil est exporté aux Etats-Unis ou au Canada, utiliser le cordon d'alimentation portant la mention UL LISTED/CSA LABELLED et remplissant les conditions suivantes:

### SPECIFICATIONS

Type de fiche	Fiche Nema 5-15 broches
Cordon	Type SVT ou SJT, minimum 3 x 18 AWG
Longueur	Maximum 15 pieds
Tension	Minimum 7A, 125V

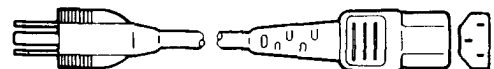

This monitor is Energy Star Compliant when used with a computer equipped with VESA Display Power Management Signaling (DPMS). The Energy Star emblem does not represent EPA endorsement of any product or service.

Before operating the unit, please read this manual thoroughly and retain it for future reference.

## Table of Contents

Introduction .....	3
Precautions .....	4
Checklist .....	4
Getting Started .....	5
Using Your Monitor .....	6
Preset and User Modes .....	6
Function of Controls .....	7
Adjustments .....	8
Normal Operation Mode .....	8
Adjustment Mode .....	8
On the Hue and Saturation Adjustment .....	11
Entering New Timings .....	12
Power Saving Function .....	12
Use of the Tilt-Swivel .....	12
Troubleshooting .....	13
Specifications .....	14

## Introduction

---

Congratulations on your purchase of a Sony Multiscan SE series monitor! This monitor incorporates over 25 years of Sony experience with Trinitron display technology, ensuring excellent performance and outstanding reliability. The advanced design of the SE series together with Digital Multiscan Technology allows the monitor to automatically adjust its display parameters to maximize picture quality for any frequency within its wide scan range. In addition, its three factory preset color modes and one user adjustable color mode gives you unprecedented flexibility in matching on screen colors to hard copy printouts. Furthermore, the SE series features digital controls, raster rotation, Energy Star power saving, low emissions, and much more. All together, it delivers incredible performance with the quality and support you can expect from a Sony.

# Precautions

---

## Installation

- Prevent internal heat build-up by allowing adequate air circulation. Do not place the unit on surfaces (rugs, blankets, etc.) or near materials (curtains, draperies) that may block the ventilation holes.
- Do not install the unit near heat sources such as radiators or air ducts, nor in a place subject to direct sunlight, excessive dust, mechanical vibration or shock.
- Do not place the unit near equipment which generates magnetism, such as a converter or high voltage power lines.

## Warning on Power Connection

- Use the supplied power cord.

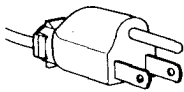

for 100 to  
120 V AC

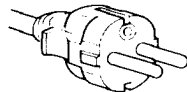

for 220 to  
240 V AC

- To disconnect the power cord, wait for at least 30 seconds after turning off the power for discharging the static electricity on the CRT display surface.
- After the power has been turned on, the CRT is demagnetized for approximately 5 seconds. This generates a strong magnetic field around the bezel which may affect the data stored on magnetic tape or disks near the bezel. Place such magnetic recording equipment and tapes/disks apart from this unit.

The socket-outlet shall be installed near the equipment and shall be easily accessible.

## Maintenance

Clean the cabinet, panel and controls with a soft cloth lightly moistened with a mild detergent solution. Do not use any type of abrasive pad, scouring powder or solvent, such as alcohol or benzene.

# Checklist

---

Before using this monitor, please make sure that the following items are included in your package:

Monitor (1)

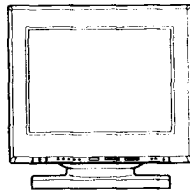

Power cord (1)

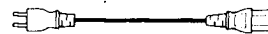

Universal MacView adapter  
with manual (1)



Video signal cable (1)

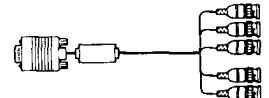

Warranty Card (1)

This Operating Instruction manual (1)

Monitor Adjustment Reference Card (1)

# Getting Started

This monitor will sync with any IBM or compatible system equipped with VGA or greater graphics capability. Although this monitor will sync to other platforms, including Macintosh and Power Macintosh system, a cable adapter is required. Please consult your dealer for advice on which adapter is suitable for your needs.

**Step one:** With the monitor switched off, attach the power cord to the monitor and the other end to the power outlet.

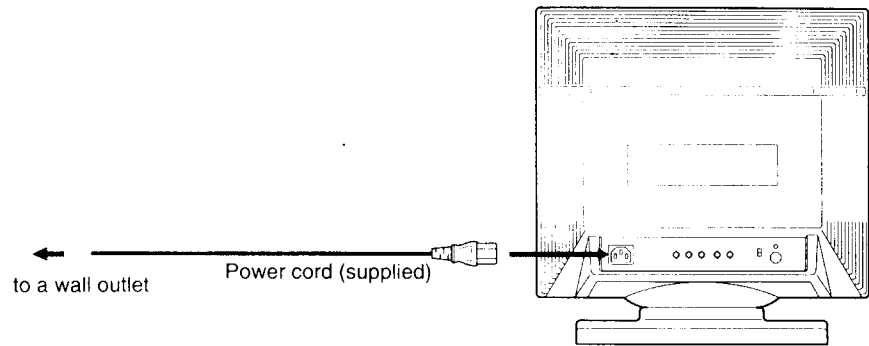

**Step two:** With the computer switched off, attach the video signal cable to the monitor (5 BNC's) and attach the other end to the video card.

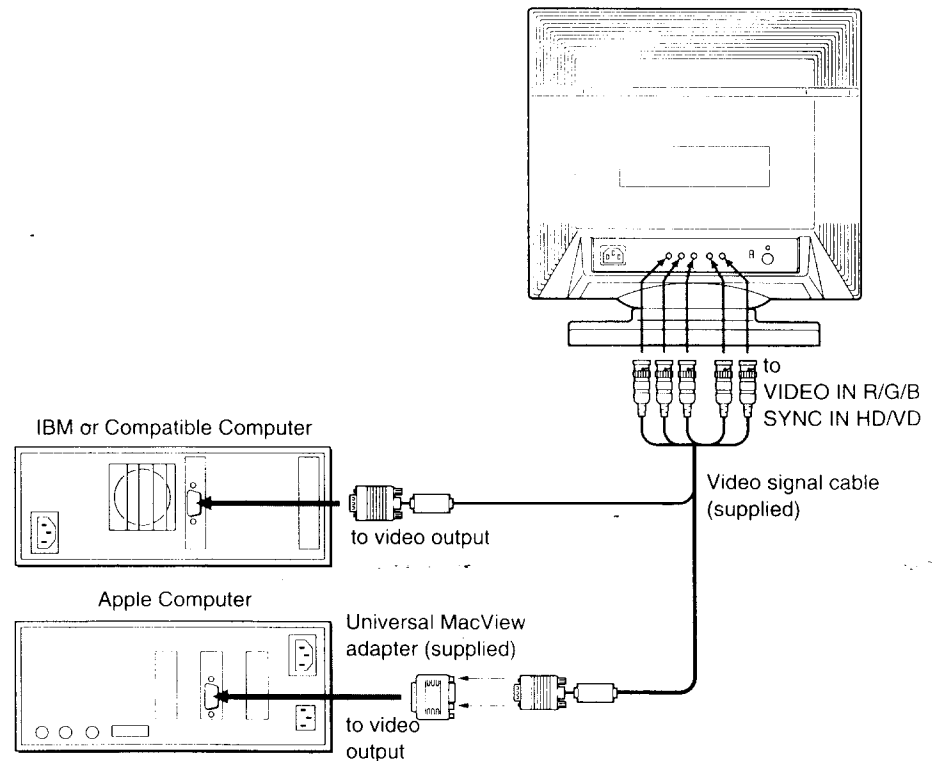

**Step three:** Turn on the monitor and computer.

**Step four:** If necessary, adjust the user controls according to your personal preference.

The installation of your monitor is complete. Enjoy your monitor.

# Using your Monitor

---

## Preset and User Modes

The Multiscan 17se/20se has factory preset modes for the 9 most popular industry standards for true "plug and play" capability.

NO.	Resolution (dots × lines)	Horizontal Frequency	Vertical Frequency	Graphics Mode
1	640 × 480	31.5 kHz	60 Hz	VGA Graphic <sup>1)</sup>
2	720 × 400	31.5 kHz	70 Hz	VGA Text <sup>1)</sup>
3	800 × 600	46.9 kHz	75 Hz	VESA <sup>2)</sup>
4	832 × 624	49.7 kHz	75 Hz	Macintosh 16" Color <sup>3)</sup>
5	1024 × 768	60 kHz	75 Hz	VESA <sup>2)</sup>
6	1024 × 768	60 kHz	75 Hz	Macintosh 19" Color <sup>3)</sup>
7	1152 × 870	68.7 kHz	75 Hz	Macintosh 21" Color <sup>3)</sup>
8	1280 × 1024	64 kHz	60 Hz	STD CAD/CAM
9	1280 × 1024	80 kHz	75 Hz	VESA <sup>2)</sup>

1) VGA is a trademark of IBM Corporation.

2) VESA is a trademark of the non-profit organization, Video Electronics Standard Association.

3) Macintosh is a trademark of Apple Computer Inc.

**Note:** For Windows 3.x users, check your video board manual or the utility program which comes with your graphic board and select the highest available refresh rate to maximize monitor performance.

For less common modes, and modes that evolve in the future, the Digital Multiscan Technology of the Multiscan SE series will perform all of the complex adjustments necessary to ensure a high quality picture for any timing in its frequency range. However, due to the wide variety of video boards on the market, it may be necessary for the user to fine tune the vertical/horizontal size and centering.

### Recommended horizontal timing conditions

Horizontal sync width should be: >1.0 μsec.

Horizontal blanking width should be: >3.0 μsec.

# Function of Controls

See the given pages for further description.

Front

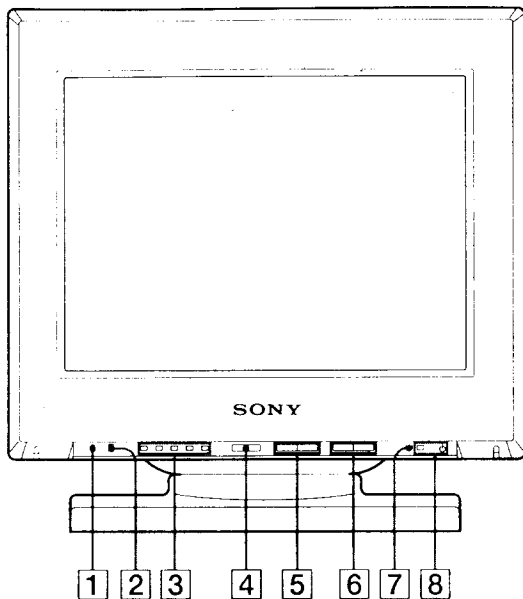

Rear

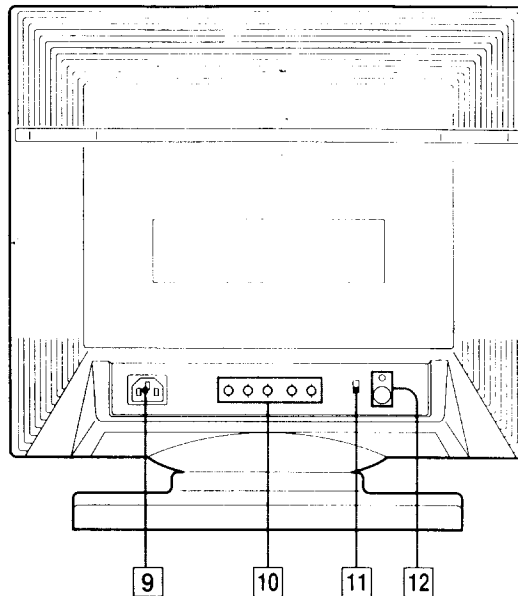

- 1 RESET button**  
Recalls certain factory settings. See "Adjustments" section for details (page 8).
- 2 CTRL (control) button**  
Extends RESET and SELECT adjustment function. See "Adjustments" section for details (page 8).
- 3 LED indicators**  
CENT: Centering (page 9)  
SIZE: Picture size (page 9)  
GEOM: Raster rotation/Horizontal pincushion (page 9)  
CONV: Convergence (page 9)  
C TEMP: Color temperature/Hue/Saturation (page 10)
- 4 SELECT button**  
Selects an adjustment item (page 9).
- 5 ○ (brightness) +/- adjustment buttons**  
Adjusts the picture brightness in normal operation mode (page 8).  
Acts as "+/-" controls in adjustment mode. See "Adjustments" section for details (page 8).
- 6 ● (contrast) +/- adjustment buttons**  
Adjusts the picture contrast in normal operation mode (page 8).  
Acts as "+/-" controls in adjustment mode. See "Adjustments" section for details (page 8).

- 7 POWER SAVING indicator**  
Illuminates when the monitor is in Power Saving Mode. Flashes when the limit value for an adjustment is reached.
- 8 ⏻ power switch and indicator**  
Turns the monitor on and off. The indicator illuminates when the monitor is turned on.
- 9 AC inlet**  
Input for the supplied AC power cord.
- 10 Video input connectors (BNC)**  
Accepts RGB video and sync signals.

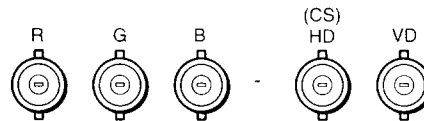

- 11 75Ω/2 kΩ selector**  
Switches the impedance of the video input connector **10** termination to 75Ω or to 2 kΩ. This monitor is initially set to 2 kΩ, which is appropriate for the majority of IBM compatible and Macintosh systems. For unique systems, which may require 75Ω, consult your dealer.
- 12 SERVICE button and terminal**  
This button and terminal are to be used by service personnel only.

# Adjustments

---

A number of digital controls are provided to allow you to optimize the display parameters to your preferences. In addition to the following adjustment directions, a Monitor Adjustment Reference Card has been provided for your convenience. Please place it in an easily accessible location near your monitor.

## Normal Operation Mode

### Brightness Adjustment

---

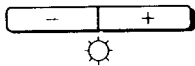

Using the  adjustment buttons, Press "+" for more brightness. Press "-" for less brightness.

### Picture Contrast Adjustment

---



Using the  adjustment buttons, Press "+" for more contrast. Press "-" for less contrast.

- When the limit value is reached, the POWER SAVING indicator will begin to flash.
- Press the RESET button to recall the factory settings for brightness and picture contrast. See "Caution" below.
- Note: The brightness and contrast settings are common for all video timings.

## Adjustment Mode

To leave Normal Operation Mode and enter Adjustment Mode, press and hold the SELECT button until the "CENT" LED indicator illuminates. You can then press the SELECT button to choose any of the five adjustments and use the "+" and "-" buttons as described on the following pages to fine tune your monitor.

The Centering, Size and Pincushion Geometry adjustments are unique to each mode while the Raster Rotation, Convergence, and Color Temperature adjustments are common to all modes.

- When the limit value is reached, the POWER SAVING indicator will begin to flash.
- Adjustments will be stored automatically and the monitor will return to the Normal Operation Mode after 8 seconds of non-use.

### CAUTION:

In adjustment mode, pressing the RESET button recalls the factory settings for Size, Centering and Pincushion Geometry for the current mode, and Raster Rotation, Convergence and Color Temperature, which is common to all modes. Pressing the CTRL and RESET buttons together clears all user-defined data in memory.



## Centering Adjustment

1

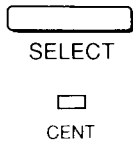

1 Use the SELECT button to illuminate the "CENT" LED.

2

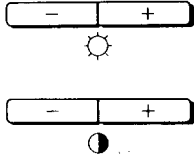

2 With the "CENT" indicator illuminated...  
Adjust the vertical centering ☀ using the ⬆ ⬇ buttons.  
Press "+" to move up.  
Press "-" to move down.  
Adjust the horizontal centering ○ using the ⬅ ➡ buttons.  
Press "+" to move to the right.  
Press "-" to move to the left.

## Picture Size Adjustment

1

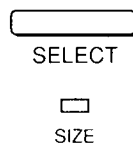

1 Use the SELECT button to illuminate the "SIZE" LED indicator.

2

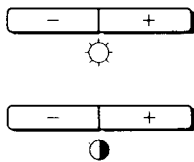

2 With the "SIZE" indicator illuminated...  
Adjust the vertical size Ⓢ using the ⬆ ⬇ buttons.  
Adjust the horizontal size ☷ using the ⬅ ➡ buttons.  
Press "+" to enlarge.  
Press "-" to diminish.

## Geometry Adjustment

1

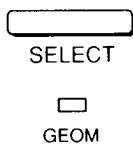

1 Use the SELECT button to illuminate the "GEOM" LED indicator.

2

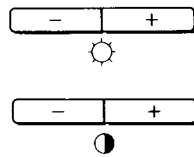

2 With the "GEOM" indicator illuminated...  
Adjust the Raster Rotation ○ using the ⬆ ⬇ buttons.  
Press "+" to rotate clockwise.  
Press "-" to rotate counterclockwise.  
Adjust the Pincushion (Bowing of the sides) ☷ using the ⬅ ➡ buttons.  
Press "+" to expand the picture sides.  
Press "-" to diminish the picture sides.

## Color Convergence Adjustment

1

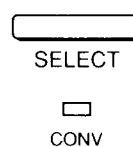

1 Use the SELECT button to illuminate the "CONV" LED indicator.

2

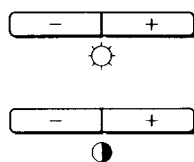

2 With the "CONV" indicator illuminated...  
Adjust the vertical convergence ☷ using the ⬆ ⬇ buttons.  
Press "+" to move Red color upward and Blue color downward.  
Press "-" to move Red color downward and Blue color upward.  
Adjust the horizontal convergence ☷ using the ⬅ ➡ buttons.  
Press "+" to move Red color to the right and Blue color to the left.  
Press "-" to move Red color to the left and Blue color to the right.

# Adjustments

## Color Temperature Adjustment

This feature is provided so that you can choose a white point that is suitable to your application or personal preference. The monitor comes from the factory in the 9300 K mode, which is indicated by the "C TEMP" LED flashing once/second. The four modes can be distinguished as follows:

C TEMP indicator	Mode	Whiteness	Adjustments
1 flash/second	9300 K	Bluish	Not available
2 flash/second	6500 K	Neutral	Not available
4 flash/second	5000 K	Yellowish	Not available
Solid orange	User-adjustable	Variable	Hue and Saturation

### To select preset color temperature

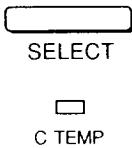
- 1** 

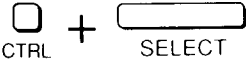
**1** Use the SELECT button to illuminate the "C TEMP" LED indicator.
- 2** 

**2** With the indicator illuminated, press the CTRL and SELECT buttons together to switch between the one user-adjustable and three factory preset modes.

### To adjust color temperature in User-adjustable mode

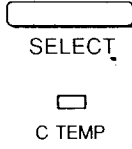
- 1** 

**1** Use the SELECT button to illuminate the "C TEMP" LED indicator.
- 2** 

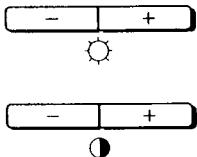
**2** If necessary, press CTRL and SELECT button together to switch to the user-adjustable mode (Solid orange LED).
- 3** 

**3** With the LED illuminated...  
Adjust the Hue using the ○ buttons.  
Adjust the Saturation using the ● buttons.  
See "On the Hue and Saturation Adjustment" for further information.

## On the Hue and Saturation Adjustment

The user-adjustable mode allows you to adjust the hue and saturation to obtain a color temperature other than the factory settings of 9300 K, 6500 K and 5000 K, and consequently a different white. The illustration below describes how the colors are arranged to reproduce white.

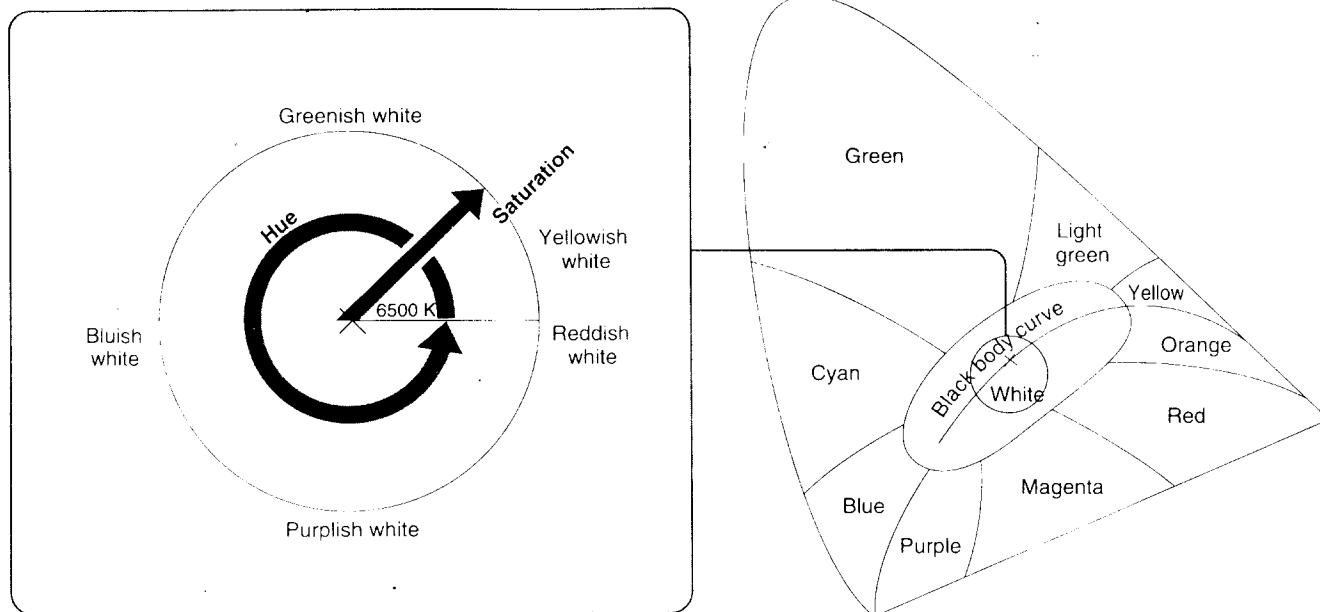

The hue controls adjust in the circular direction.  
The saturation controls adjust along radial axes from the center.

When you want to change the hue and saturation...

- 1 Press **+** until the saturation becomes the maximum.
  - 2 Adjust the hue using the **○** buttons.  
Pressing "+" goes: Red → Green → Blue → Red  
Pressing "-" goes: Red → Blue → Green → Red
  - 3 Adjust the saturation using the **○** buttons to your desired color.
- The user-adjustable mode comes from the factory initially set to 6500 K.

### If the background of the picture is too bright or greenish

1 **○** + **○**  
CTRL SELECT

With certain video signals, the background level may appear too bright or greenish. If the brightness controls cannot correct the problem, reset the clamp pulse to obtain the correct black back-ground level.

2 **○** - **○** +  
○

1 While holding down the CTRL button, press the SELECT button for 2 seconds.  
All indicators except CENT illuminate.

2 Choose between the 2 settings using the **○** +/- buttons.

# Entering New Timings

When using a video mode that does not match one of the 9 factory preset modes, some fine tuning may be required to optimize the display to your preferences. Simply adjust the monitor according to the preceding adjustment instructions. The adjustments will be stored automatically and recalled whenever that mode is used.

A total of 11 user-defined modes can be stored in memory. If a 12th mode is entered, it will replace the first.

# Power Saving Function

This monitor is capable of 2 states of reduced power consumption.

By sensing the absence of one or both sync signals coming from the host computer, it will reduce power consumption as follows.

	State	Power consumption	Required resumption time	Power indicator	POWER SAVING indicator
1	Normal operation	100%	—	green on	off
2	Suspend (1st step of power saving)	approx. 10%	approx. 3 sec.	green on	orange on
3	Active-off (2nd step of power saving)	approx. 7%	approx. 10 sec.	off	orange on

## Power Saving Operation

The H-sync or V-sync is not present.



The unit goes into suspend state.

Both the H-sync and V-sync are not present.



The unit goes into active-off state.

The monitor requires a videocard or screen saver software which switches off one or both sync signals to activate the power saving function.

**CAUTION:** The Power Saving function will automatically put the monitor into the Active-off state if the power switch is turned on without any video signal input. Once the horizontal and vertical syncs are sensed, the monitor will automatically return to its Normal operation state.

# Use of the Tilt-Swivel

With the tilt-swivel, this unit can be adjusted to be viewed at your desired angle within 90° horizontally and 20° vertically. To turn the unit vertically and horizontally, hold it at its bottom with both hands and push in the desired direction. The tilt-swivel can not be removed.

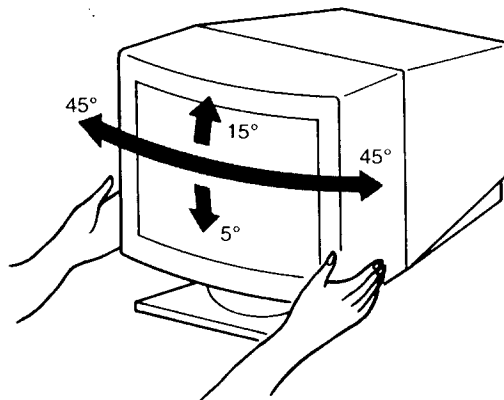

# Troubleshooting

This section may help you isolate the problem and as a result, eliminate the need to contact technical support and allow continued productivity.

Symptom	Check these items
No picture	
If neither $\odot$ (power) indicator nor POWER SAVING indicator is lit	<ul style="list-style-type: none"> <li>• Check that the power cord is properly connected.</li> <li>• Check that the power switch is in the "ON" position.</li> </ul>
If POWER SAVING indicator is lit	<ul style="list-style-type: none"> <li>• Check that your computer power switch is in the "ON" position.</li> <li>• Check that the video cable is properly connected and all plugs are firmly seated in their socket.</li> <li>• Check that the 5 BNC's are connected in the right order. (from power cord side: Red-Green-Blue-HD-VD)</li> <li>• Ensure that no pins are bent or pushed in the HD15 connector of the cable.</li> <li>• Check that the video card is seated completely in a proper bus slot. There may be a particular bus slot specified for your video board to be seated among 8, 16, and VL-Bus slots.</li> <li>• If the impedance switch on the back of the monitor is set to 75 <math>\Omega</math>, try switching to 2 k<math>\Omega</math> or vice versa.</li> <li>• Check that the video frequency range is within that specified for the monitor.</li> <li>• If using a Mac system, check that a proper HD15-D15 adapter is provided to work correctly with your Mac.</li> </ul>
If $\odot$ (power) and POWER SAVING indicators are both flashing	<ul style="list-style-type: none"> <li>• If the impedance switch on the back of the monitor is set to 75 <math>\Omega</math>. Turn off the monitor, move the switch to 2 k<math>\Omega</math>, and turn the monitor on. If the indicators are still flashing, there is a potential monitor failure. Contact your dealer.</li> </ul>
If your computer is a Macintosh system.	<ul style="list-style-type: none"> <li>• Check that micro switches are properly set on the Macintosh adapter for your system. (See the adapter manual.)</li> </ul>
Picture is scrambled	<ul style="list-style-type: none"> <li>• If the impedance switch on the back of the monitor is set to 75 <math>\Omega</math>, try switching to 2 k<math>\Omega</math> or vice versa.</li> <li>• Check your graphics board manual for proper monitor setting on your Multiscan SE series monitor.</li> <li>• Check this manual and confirm that the graphic mode and frequency at which you are trying to operate is supported. Even within range some video boards may have a sync pulse that is too narrow for the monitor to sync correctly.</li> </ul>
Color is not uniform	<ul style="list-style-type: none"> <li>• Trip the power switch once to activate Auto-degauss cycle. This function is to demagnetize the metal frame of the CRT to obtain neutral field for uniform color reproduction. If a second degauss cycle is needed, allow a minimum interval of 20 minutes for the best result.</li> </ul>
White does not look white	<ul style="list-style-type: none"> <li>• Check that the 5-BNC's are connected in the right order. (from power cord side: Red-Green-Blue-HD-VD)</li> <li>• Perform color temperature adjustment (page 10).</li> <li>• If the video format is not listed in the compatibility table on page 6, there may be a background level problem (background too bright or greenish). Try black level toggle switch (page 11).</li> <li>• If your computer is a Macintosh system, check that micro switches are properly set on the Macintosh adapter for your system. (See the adapter manual.)</li> </ul>
Screen image is not centered or sized properly	<ul style="list-style-type: none"> <li>• Adjust "Centering", "Size" or "Raster Rotation" control (page 9).</li> <li>• Some video modes do not fill the screen to the edge of the monitor. There is no single answer to solve the problem. There is a tendency to have this problem on higher refresh timings and Macintosh video timings.</li> </ul>

To be continued

# Troubleshooting

Symptom	Check these items
Sides of the image are curved	<ul style="list-style-type: none"> <li>Adjust the "Pincushion" control in "Geometry" adjustment mode (page 9).</li> </ul>
White lines show red or blue shades at edges	<ul style="list-style-type: none"> <li>Adjust the "Convergence" controls (page 9).</li> </ul>
Picture is fuzzy	<ul style="list-style-type: none"> <li>Adjust the "Contrast" and "Brightness" controls (page 8). We have come across several brands of SVGA boards that have excessive video output level which creates fuzzy picture at max contrast.</li> <li>Trip the power switch once to activate Auto-degauss cycle. This function demagnetizes the metal frame of the CRT to obtain neutral field for uniform color reproduction. If a second degauss cycle is needed, allow a minimum interval of 20 minutes for the best result.</li> <li>If red or blue shades are found at the edge of images, adjust the "Convergence" controls (page 9).</li> </ul>
Picture bounces or has wavy oscillations	<ul style="list-style-type: none"> <li>Isolate and eliminate any potential sources of electric or magnetic fields. Common causes for this symptom are electric fans, fluorescent lighting, laser printers, and so on.</li> <li>If you have another monitor set close to this monitor, increase the distance between them to reduce the interference.</li> <li>Try plugging the monitor into a different AC outlet, preferably on a different circuit.</li> <li>Try the monitor on a completely different computer in a different room.</li> </ul>
Picture appears to be ghosting.	<ul style="list-style-type: none"> <li>Eliminate the use of video cable extension cable and/or video switch boxes if this symptom occurs. Excessive cable length or weak connections can produce this symptom.</li> </ul>
Two fine horizontal lines (wires) are visible	<ul style="list-style-type: none"> <li>These wires stabilize the vertically striped Aperture Grille. This Aperture Grille allows more light to pass through to the screen giving the Trinitron CRT more color and brightness.</li> </ul>
Wavy or elliptical (moire) pattern is visible.	<ul style="list-style-type: none"> <li>Due to the relationship between resolution, monitor dot pitch and the pitch of some image patterns, certain screen backgrounds, especially gray, sometimes show moire. This can only be eliminated by changing your desktop pattern.</li> </ul>

- If your question concerns the features, specifications or compatibility of the monitor, contact Sony Technical Support. If the monitor appears to have malfunctioned, contact your nearest Sony Service Center.
- Note the model name and the serial number of your monitor. Also note the make and name of your computer and video board.

# Specifications

## GDM-17SE1

Picture tube	0.25 mm aperture grille pitch 17 inches measured diagonally (16" maximum viewing image) 90-degree deflection
Video image area	Approx. 328 × 242 mm (w/h) (13 × 9 <sup>5</sup> / <sub>8</sub> inches)
Resolution	Horizontal: Max. 1280 dots Vertical: Max. 1024 lines
Standard image area	Approx. 293 × 234 mm (w/h) (11 <sup>5</sup> / <sub>8</sub> × 9 <sup>1</sup> / <sub>4</sub> inches) or Approx. 300 × 225 mm (w/h) (11 <sup>7</sup> / <sub>8</sub> × 8 <sup>7</sup> / <sub>8</sub> inches)
Deflection frequency	Horizontal: 31.5 to 82 kHz Vertical: 50 to 150 Hz
AC input voltage/current	100 to 120 V, 50/60 Hz, 2.7 A 220 to 240 V, 50 – 60 Hz, 1.5 A
Dimensions	406 × 414 × 450 mm (16 × 16 <sup>3</sup> / <sub>8</sub> × 17 <sup>3</sup> / <sub>4</sub> inches)
Mass	Approx. 22.5 kg (49 lb 8 oz)

## GDM-20SE1

Picture tube	0.30 mm aperture grille pitch 20 inches measured diagonally (19" maximum viewing image) 90-degree deflection
Video image area	Approx. 388 × 292 mm (w/h) (15 × 11 <sup>1</sup> / <sub>2</sub> inches)
Resolution	Horizontal: Max. 1280 dots Vertical: Max. 1024 lines
Standard image area	Approx. 350 × 280 mm (w/h) (13 <sup>7</sup> / <sub>8</sub> × 11 <sup>1</sup> / <sub>8</sub> inches) or Approx. 373 × 280 mm (w/h) (14 <sup>3</sup> / <sub>4</sub> × 11 <sup>1</sup> / <sub>8</sub> inches)
Deflection frequency	Horizontal: 31.5 to 85 kHz Vertical: 50 to 150 Hz
AC input voltage/current	100 to 120 V, 50/60 Hz, 3.0 A 220 to 240 V, 50 – 60 Hz, 1.8 A
Dimensions	474 × 474 × 501.5 mm (18 <sup>3</sup> / <sub>4</sub> × 18 <sup>3</sup> / <sub>4</sub> × 19 <sup>3</sup> / <sub>4</sub> inches)
Mass	Approx. 30 kg (66 lb 2 oz)